

**SEAT & FRAMING PLAN**

1/4" = 1'-0"  
20 NET SEATS @ 18" PER SEAT

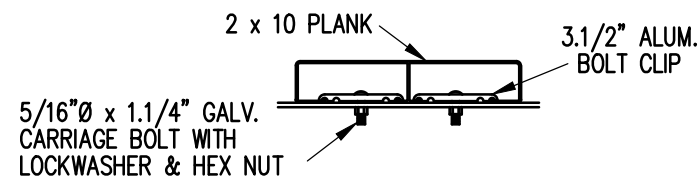

**BOLT CLIP DETAIL**

1.1/2" = 1'-0"

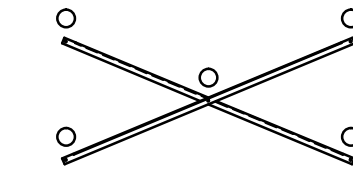

**X-BRACE DETAIL**

N.T.S.

○ 7/16" X 1" GALV. MACH. BOLT

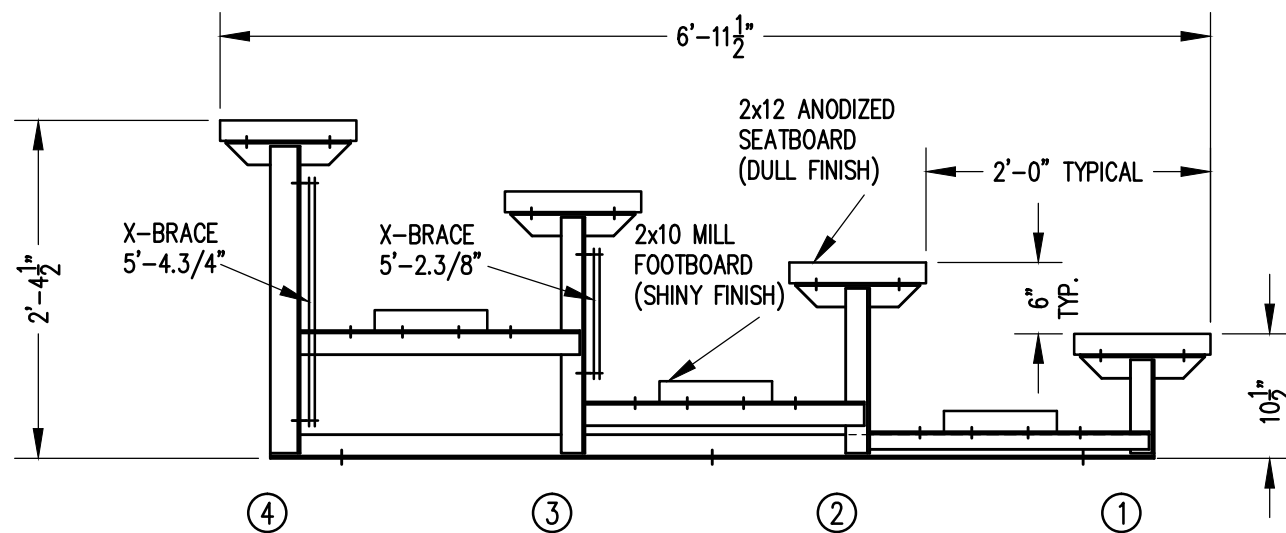

**SECTION AA**

3/4" = 1'-0"

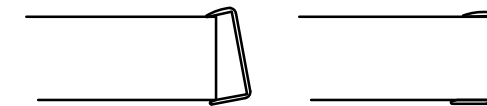

FIG.1

FIG.2

- 1) LOCATE THE CHANNEL END CAP AS SHOWN IN FIG. 1.
- 2) TAP END CAP INTO PLACE WITH RUBBER Mallet OR SOFT WOOD. FIG.2
- 3) DRILL 5/32" HOLES THROUGH THE BOTTOM FLANGE AND THE BOTTOM OUTSIDE PLANK FLANGES OF EACH PLANK. INSTALL 5/32" POP RIVETS.

**END CAP DETAIL**

N.T.S.



SCALE	REVISIONS	BY	DA
DATE 1/26/2016			
DR'N CKD			
AP'VD			
TITLE	NO.		